



Thank you for purchasing "KOSO XR-SR N DIGITAL LCD meter". Before installing, please check the instruction carefully.

Notice

1. The lcd meter is apply for **DC 12V**.
2. For installation, please follow the steps described in manual. Any damage caused by wrong installation shall be imputed to the users.
3. To avoid the short circuit, please don't pull the wire when installing. Don't break or modify the wire terminal.
4. Do not disassemble or change any parts excluding the manual description.
5. The interior examination or maintenance should be executed by our professionals.

MARK MEANING:

NOTE You could get the installation details from the information behind the mark.

! Some processes must be followed to avoid the affection caused by wrong installation.

! WARNING! Some processes must be followed to avoid damages to yourself or the public.

! CAUTION! Some processes must be followed to avoid the damage to the vehicle.



PRESS THE
BUTTON ONE TIME



PRESS THE
BUTTON 3
SECONDS

1-1 Accessory

<p>1 Lcd meter X 1</p>	<p>2 RPM wire set (Type A) X 1</p>	<p>3 RPM wire set (Type B) X 1</p>	<p>4 Temp sensor wire set X 1</p>
<p>5 PT 1/8 water temp sensor X 1</p>	<p>6 Digital speed signal sensor X 1</p>	<p>7 D6x5/ mm magnet X 6</p>	<p>8 Connect terminal X 12</p>
<p>9 M8/ S type speed sensor bracket X 1</p>	<p>10 M10/ S type speed sensor bracket X 1</p>	<p>11 Hexagon socket screw X 2</p>	<p>12 2.5 mm spanner X 1</p>
<p>13 4 mm spanner X 1</p>	<p>14 Meter bracket (for handle bar)</p>	<p>15 M5 washer X 3</p>	<p>16 M5 X 12L screw X 2</p>
<p>17 M5 X 18L screw X 3</p>	<p>18 Manual</p>		

NOTE Please contact the local distributor if the items you open are not the same, with the above-listed one.

1-2 Option accessory

<p>1 Oil temp sensor adapter</p> <p>M12 X P1.5 X 15L M14 X P1.25 X 15L M14 X P1.5 X 15L M16 X P1.5 X 15L M18 X P1.5 X 15L M20 X P1.0 X 15L M20 X P1.5 X 15L</p>	<p>2 Water temp sensor adapter</p> <p>M14 M16, M18 M22, M26mm</p>	<p>3 Cylinder head temp sensor</p> <p>M10, M14mm</p>	<p>4 Temp sensor</p> <p>M10 X P1.0 M12 X P1.5 M14 X P1.25 M14 X P1.5 M16 X P1.5 / M18 X P1.5</p>
<p>5 Disc magnet screw</p> <p>5r16-18 X 22-4L M5 X P0.8 X 12L M6 X P1.0 X 12-4L M6 X P1.0 X 19-7L M6 X P1.0 X 24L M8 X P1.25 X 22-5L M8 X P1.25 X 27-5L M8 X P1.25 X 29L M10 X P1.25 X 28-3L</p>	<p>6 Meter bracket (for stem)</p>		

NOTE Some of the option accessories may not sell. For the details, please contact the local distributor.

2-1 Wiring installation instructions

Wiring diagram showing connections for the instrument cluster. Key components include:

- Red / Positive pole (Connect to the battery DC 12V)
- Black / Ground wire (connect to the vehicle body or the engine (It must be a good ground))
- Brown / + Wire connect key on DC 12V main power switch
- Orange / Left winker (+12V)
- Green / Low beam (+12V)
- Yellow / High beam (+12V)
- Light blue / Neutral (-)
- Deep green / Fuel (-)
- Blue / Right winker (+12V)
- Gray / Oil pressure (+12V/-)
- Purple / Water temperature (+12V)
- BROWN / Hazard (+12V)
- Digital speed signal sensor (Accessory 3)
- RPM wire set-type A (Accessory 2)
- RPM wire set-type B (Accessory 3)
- Magnet (Accessory 7)
- Ignition control box
- Spark plug wire
- The ignition coil positive electrode

Main switch wiring reference:

	~+ Color	~- Color
YAMAHA	Brown	Black
HONDA	Brown	Black
SUZUKI	Black	Green
SYM	Black	Green

Fuel Indicator wiring reference:

YAMAHA	HONDA	SUZUKI	SYM
Green	Yellow/white	Yellow/white	Yellow/white

NOTE The color listed above may differ depending on the model.

NOTE The fuel sensor is electronic type, please don't parallel connection with the original, otherwise the fuel gauge won't display. The wrong installation of the fuel wiring may cause the meter break.

NOTE When connecting the power wiring, please follow the instruction, if you connect the red & brown wiring in parallel will cause the meter work improperly.

NOTE We provide 3 ways to get the RPM signal from spark plug wire, the coil, or the pick-up on ignition control box, if there are interruptions, you could change the sensor wiring to get better signal.

CAUTION! Just wrap the RPM wire (A) around the spark plug wire. Do not connect them! We also suggest you to replace the "R" type spark plug in the mean time to get better signal. For the model more than one piston, please catch the signal from the first cylinder coil wire. For the model with more than one piston, please just connect the rpm sensor wiring to one of the ignition coil positive electrodes. Please make sure that the ignition coil positive electrode before connecting the RPM sensor wiring! Wrong installation will cause the meter broken!

NOTE The north (N) side of magnet must face to the sensor when installing.

NOTE If you don't connect the fuel wiring, the fuel gauge will not display.

2-2 Installation instructions

- Put the magnet into the brake disc screw hole.
- Install the S type sensor bracket.
- Adjust the sensor bracket position to make sure that the sensor could face the magnet to prevent bad speed signal or no signal!
- Install the speed sensor on the bracket.
- Adjust the distance between sensor and magnet. We suggest you to make sure the distance is under 8mm for catching good speed signal.

You could make the speed more precise by adding the magnets. when installing the magnet, please put the magnet with N-mark side face the outside and put them averagely to avoid wrong signal.

EX. 1: If your disk has 3 screws, you could install 1 or 3 magnets to catch the speed.

EX. 2: If your disk has 4 screws, you could install 1 - 2 or 4 magnets to catch the speed.

EX. 3: If your disk has 5 screws, you could install 1 or 5 magnets to catch the speed.

EX. 4: If your disk has 6 screws, you could install 1 - 2 - 3 or 6 magnets to catch the speed.

After finishing the magnet installation and sensor point setting, please move your tire to test the speedometer work or not.

3-1 Basic function instruction

Fuel symbol

- Display range: 10 levels.
- The fuel reserve symbol begins to flash if only 3 grids left.

Thermometer

- Display range: 20-120°C (68-248°F), and display as 10 level.
- Display unit: one level is similar to 10°C (50°F).

Odo meter

- Display range: 0-99999 km (mile), reset automatically after 99999 km.
- Display unit: 1 km (mile).

Trip meter A.B

- Display range: 0-999.9 km (mile), reset automatically after 999.9 km.
- Display unit: 0.1 km (mile).

Tachometer

- Display range: 0-18000 RPM.
- Display unit: 100 RPM.

Speedometer

- Display range: 0-360 km/h (0-223 MPH)
- Display unit: km/h or MPH.

thermometer

- Display range: 0-120°C (32-248°F)
- Display unit: 0.1°C (°F).

Clock

- 24H

MAX record

- The meter will record the top speed, RPM and temperature automatically.

3-2 Function, setting instruction

● Speed unit	km/h / MPH alternative
● Speedometer range	0~360km/h (0~223 MPH)
○ Display internal	<0.5 second
○ Odometer	0~99999 km (mile)
○ Trip A, B	0~999.9 km (mile)
○ Top speed record	0~360 km/h (0~223 MPH)
○ Tire circumference setting	1000~2500 m/m · Adjust unit: 1 m/m Sensor point: 1~6
● Tachometer range	0~18000 RPM · Display unit: 100 RPM
○ Display internal	<0.5 second
○ MAX RPM record	0~15000 RPM
○ Stroke / piston setting	2 Stroke: 1, 2, 3, 4 pistons 4 Stroke: 1, 2, 3, 4, 5, 6, 8, 10, 12 pistons
● Temperature unit	°C、°F
● Digital water temperature range	0~120°C (32~248°F) · Display unit: 0.1°C (0.1°F)
● Temperature level gauge display range	20~120°C (68~248°F), display in 10 level · Display unit: 1 level=10°C (50°F)
○ Display internal	<0.5 second
○ Top temperature record	0~120°C (32~248°F)
● Fuel gauge	Display in 10 levels (one level means 10% fuel)
○ Fuel resistance setting	100 Ω · 510 Ω
● Clock	24 H

● Top speed timer	The record including, Speed : 0~360 km/h (0~223 MPH). Distance : 0~999 m (0~3280 feet). Timer : 0~9'59"99 second.
● Effective voltage	DC 12V
● Effective temperature range	-10~+60°C
● Meter standard	JIS D 0203
● Meter size	116.3 X 72.4 X 32.3 m/m
● Meter weight	Around 286 g
● Indicator light	Neutral (green light /-), High beam (blue light /+) Low beam (green light /+), Winker (green light /+) Hazard (Red light /+), Oil pressure (Red light /-) Water temperature light (Red light /+)

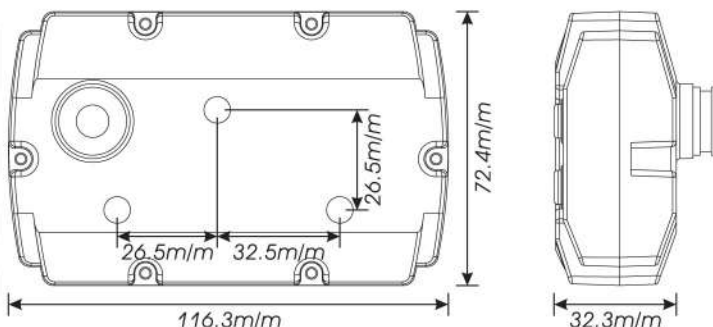

NOTE Design and specification are subject to change without notice!

3-3 The button function instruction

SELECT BUTTON

1. In main screen, press the **Select** button to choose the display of clock, water temperature or oil temperature.
2. In setting screen, press the **Select** to choose the function you want to set.

SELECT BUTTON X 3 SECONDS

1. In main screen, press down the **Select** button for 3 seconds to enter the power test screen.
2. In power test screen, press down the **Select** button for 3 seconds to back to the main screen.
3. In setting screen, press down the **Select** button for 3 seconds to back to the main screen.

ADJUST BUTTON

1. In main screen, press the **Adjust** button to choose the display of odometer,

trip A, trip B or the MAX record.

2. In power test screen, press the **Adjust** button to reset the record, stop the testing, or restart the test.
3. In setting screen, press the **Adjust** to make the number setting. If you keep pressing down the **Adjust** the setting number will increase fast.

ADJUST BUTTON X 3 SECONDS

In main screen, press down the **Adjust** button for 3 seconds to reset the trip A, trip B, or the MAX record.

PRESS DOWN THE ADJUST BUTTON

In setting screen, to add the setting value fast.

SELECT+ADJUST X 3 SECONDS

In main screen, press down the **Select** & **Adjust** buttons at the same time for 3 seconds to enter the setting screen.

CAUTION! For safety reason - only when the vehicle is stop, then you could adjust the setting or operate the function.

3-4 The screen switch instruction



In the setting screen, press down the **Select** button for 3 seconds to back to the main screen.

SELECT+ADJUST X3S



In main screen, press down the **Select** & **Adjust** button at the same time for 3 seconds to enter the setting screen.

SELECT X3S



In main screen, press down the **Select** buttons for 3 seconds to enter the power test screen.

In power test screen, press down the **Select** buttons for 3 seconds to back to the main screen.

In any screen, you could press down the **Select** buttons for 3 seconds to back to the main screen.

3-5 The main screen function switch instruction Select



In main screen, press the **Select** button and then the screen will change from water temperature gauge + fuel gauge to clock + water temperature level gauge.
EX. Now the water temperature gauge is 28.5°C, and the fuel level gauge is full.

NOTE If you don't install the fuel wiring, the fuel gauge will not display.



In main screen, press the **Select** button to switch the screen from clock + water temperature level gauge to water temperature gauge + fuel level gauge.
EX. Now the time is 12:00, and the water temperature level gauge is displayed as 21~30°C.

3-6 The main screen function switch instruction Adjust



In main screen, press the **Adjust** button to choose the function combination you want to display on the screen.

The alternative combination is as the circle we list: odometer > trip A > trip B > RPM > MAX record.



3-7 The setting screen instruction



In main screen, press down the **Select & Adjust button** at the same time for 3 seconds to enter the setting screen.



In setting screen, press the **Select button** to choose the function you want to set. The function in setting screen is in order as **speed unit, cycle and piston, temperature unit, tire circumference and sensor point, time, fuel gauge, top speed test setting** and you could finish the setting as the order. After finishing the setting, press down the **Select button** to leave the setting screen.



+1
+2
+3



+4



+5
+6



+9

+7
+8

NOTE If you enter the setting screen for 30 seconds and don't press the button, it will back to the main screen automatically.

4-1 Speed unit setting



In main screen, press down the **Select & Adjust button** at the same time for 3 seconds to enter the speed unit setting.



Press the **Adjust button** to choose the speed unit.

EX. Now the setting is km/h.

⚠ Now the speed unit is flashing!

NOTE You could choose km/h or MPH in the speed unit setting screen.

⚠ The odometer & trip meter will change together with the speed unit.



Press the **Select button** to continue the function setting.

NOTE When you leave this screen, the setting is finished.

⌂ If you just want to make this function setting, you could press the **Select button** for 3 seconds to back to the main screen.

4-2 Cycle / Piston / Input signal setting



In main screen, press down the **Select & Adjust button** at the same time for 3 seconds to enter the speed unit setting.



Press the **Select button** 1 times to enter the stroke/piston setting screen.

⚠ **CAUTION!**

- Make sure the correct strokes and pistons before setting.
- Make sure the input is correct, or the RPM output will be incorrect.
- We define the engine with the ignition system ignites every 360 degree as 2-stroke and the engine with the ignition system ignites every 720 degree as 4-stroke.
- Some 4-stroke bikes with one single piston are igniting EVERY 360 degree once, so the setting should be the same as the bike with 2-stroke and one piston engine.



Press the **Adjust button** to select the stroke. EX. Now the stroke number is flashing.

⚠ Now the stroke setting number is flashing!

NOTE You could set the stroke as 2 Cycle or 4 Cycle.

⌂ If you just want to check your setting, you could press the **Select button** for 3 seconds to back to the main screen.



Press the **Select button** to enter the piston setting screen. EX. Now the setting is changed from 2 Cycle to 4 Cycle.



Press the **Adjust button** to select the piston number.

⚠ Now the piston number is flashing.

NOTE 2 Cycle: 1, 2, 3, 4 pistons
4 Cycle: 1, 2, 3, 4, 5, 6, 8, 10, 12 pistons



Press the **Select button** to enter the signal input setting.

EX. The piston setting is changed from 1 P (piston) to 4 P (pistons).



Press the **Adjust button** to choose the input signal you want to set.

⚠ Now the input signal setting is flashing!

NOTE The input signal setting range is between HI (the positive signal) & Lo (the negative signal)

NOTE If the tachometer can't detect the signal (no RPM is displayed on the screen), you could choose another setting, and check it again.



Press the **Select button** to enter other setting screen.

EX. The input signal is changed from Lo to HI.

NOTE When you leave this screen, the setting is finished.

⌂ If you just want to make this function setting, you could press the **Select button** for 3 seconds to back to the main screen.

4-3 The temperature unit setting



In main screen, press down the **Select & Adjust button** at the same time for 3 seconds to enter the speed unit setting.



Press the **Select button** 4 times to enter the temperature unit setting screen.



Press the **Adjust button** to choose °C or °F. EX. Now the temperature unit is °C.

⚠ Now the temperature unit is flashing!

NOTE The temperature unit setting range: °C or °F.



Press the **Select button** to continue the function setting. EX. Now the temperature unit is changed from °C to °F.

NOTE When you leave this screen, the setting is finished.



If you just want to make this function setting, you could press the **Select button** for 3 seconds to back to the main screen.

4-4 Tire circumference and sensor point setting



In main screen, press down the **Select & Adjust button** at the same time for 3 seconds to enter the speed unit setting.



Press the **Select button** 5 times to enter the Tire circumference and sensor point setting screen.

⚠ CAUTION!

- Please measure the tire circumference (the tire you will install the sensor on) and make sure the number of magnet sensor point (You could install the magnet into the disc screw or the sprocket screw.)
- The speed displayed on the meter will be affected by the setting, please make sure the setting number is correct before you make the setting.

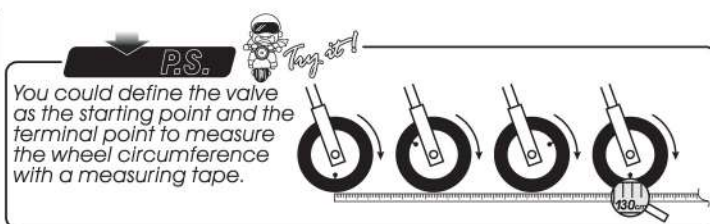

Press the **Adjust button** to choose the setting number. EX. Now the tire circumference setting is 1000 m/m, and the sensor point is 1.

⚠ Now the circumference setting number is flashing!

NOTE The tire circumference setting range: 1000~2500 m/m. Adjust unit: 1m/m.



If you just want to check your setting, you could press the **Select button** for 3 seconds to back to the main screen.



Press the **Select button** to enter the sensor point setting. EX. The circumference setting is changed from 1000 m/m to 1300 m/m.



Press the **Adjust button** to choose the setting number.

⚠ Now the sensor point setting number is flashing!

NOTE The sensor point setting range: 1~6 points.



Press the **Select button** to continue the function setting. EX. the sensor point setting is changed from 1 to 6.

NOTE When you leave this screen, the setting is finished.



If you just want to make this function setting, you could press the **Select button** for 3 seconds to back to the main screen.

4-5 The clock setting



In main screen, press down the **Select & Adjust button** at the same time for 3 seconds to enter the speed unit setting.



Press the **Select button** 7 times to enter the clock setting screen.



Press the **Select button** to enter the minute setting. EX. Now the hour is changed from 0 to 13.



Press the **Adjust button** to choose the setting number. EX. Now the time is 0:00.

⚠ Now the hour number is flashing!

NOTE This is a 24 H clock.



Press the **Adjust button** to choose the setting number.

⚠ Now the minute number is flashing!



Press the **Select button** to continue the function setting.

EX. the minute is changed from 0 to 1.

NOTE When you leave this screen, the setting is finished.



If you just want to make this function setting, you could press the **Select button** for 3 seconds to back to the main screen.

4-6 The fuel gauge resistance setting



In main screen, press down the **Select & Adjust** button at the same time for 3 seconds to enter the speed unit setting.



Press the **Select** button 9 times to enter the fuel gauge resistance setting screen.



Usually the fuel gauge resistance is 100 Ω on YAMAHA system, and 510 Ω on HONDA system.



Press the **Adjust** button to choose the setting number.
EX. Now the fuel gauge resistance setting is 100 Ω.

⚠ Now the resistance setting number is flashing!

NOTE The fuel gauge resistance setting range: 100 Ω, 510 Ω.
If you don't install the fuel wiring, the fuel gauge will not display.



Press the **Select** button to continue the function setting.
EX. Now the fuel resistance setting is changed from 100 Ω to 510 Ω.

NOTE When you leave this screen, the setting is finished.

🔄 If you just want to make this function setting, you could press the **Select** button for 3 seconds to back to the main screen.

5 Power TEST The top speed test



WARNING!
Please use this function at racetrack to avoid traffic accidents.

In main screen, press down the **Select** button 3 seconds to enter the top speed test screen.

NOTE Please start the test when the bike stops.

⚠ If you have the power test record, it will display the record first. You must clear the record before starting a new test.

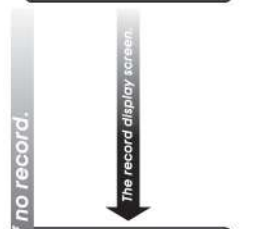

Press the **Adjust** button to clear the record and enter the top speed test screen.
EX. Now you could see the record you have before. It displays the top speed is 180 km/h, the distance to reach the top speed is 510 m, the time you need to reach the top speed is 10.20 seconds.

🔄 If you just want to check the record, you could press the **Select** button for 3 seconds to back to the main screen.



When the bike moves, the timer will start automatically.

⚠ Now the **Power** is flashing!

NOTE The top speed test range:
Speed: 0~360 km/h (0~223 MPH).
Distance: 0~999m (3280 feet).
Timer: 0~9'59"99 seconds.

⚠ The setting unit will change together with the speed unit setting (4-1).

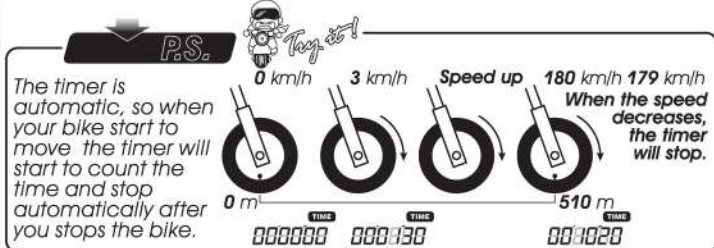

The timer is automatic, so when your bike start to move the timer will start to count the time and stop automatically after you stops the bike.

When the speed decreases, the timer will stop.



⚠ During the test, the **Power** will keep flashing!



When you reach the top speed (180 km/h), the meter will stop counting the distance (510 m), and time (10.20 seconds).

🔄 If you just want to use the function one time, press down the **Select** button for 3 seconds to save the records and back to the main screen.

If you want to test it again, press the **Adjust** button to clear the record and enter the target speed timer test screen again.

6 Trouble shooting

The following situation do not indicate malfunction of the meter. Please check the following before taking it in for repair.

Trouble	Check item
The meter doesn't work when the power is on.	<ul style="list-style-type: none"> ● The power doesn't supply to the meter. <ul style="list-style-type: none"> → Please make sure the wiring is connected. The wiring and fuse are not broken. → The battery is broken or the battery is too old to supply enough power (DC 12V) to make the meter work.
The meter shows wrong information.	<ul style="list-style-type: none"> ● Please check the voltage of your battery, and make sure the voltage is over DC 12V.
Speed does not appear or appear incorrectly.	<ul style="list-style-type: none"> ● Please make sure the speed sensor is connected correctly. ● Please check the tire-size setting. <ul style="list-style-type: none"> → please refer to the manual 4-4.

Trouble	Check item
Tachometer does not appear or appear incorrectly.	<ul style="list-style-type: none"> ● Please check the RPM sensor wiring is connected correctly. ● Please check the spark plug is "R" type or not. If not, please replace the spark plug with the "R" type spark plug. ● Please check your setting. <ul style="list-style-type: none"> → Please refer to the manual 4-2.
Fuel gauge does not appear or appear incorrectly.	<ul style="list-style-type: none"> ● Please check your fuel tank. <ul style="list-style-type: none"> → Is there any fuel inside ? ● Please check the wiring. <ul style="list-style-type: none"> → Do you connect the wiring correctly ? ● Please check the setting. <ul style="list-style-type: none"> → Please refer to the manual 4-6.
Temp does not appear or appear incorrectly. The clock is incorrect.	<ul style="list-style-type: none"> ● Please check the sensor. <ul style="list-style-type: none"> → Does the wiring break or falling off ? ● Do you connect the wiring correctly. <ul style="list-style-type: none"> → Please check the positive wire (red) connects to the battery, and main switch positive wiring (brown) connects to the main switch.

※ If still can't solve the problems according to the steps above, please contact with distributors or us.